

Positive Displacement Flowmeter

FMG Series:

Applications:

- Hydraulic Test Stand (Low Viscosity)
- Aerospace and Automobile (Low to Medium Viscosity)
- Batching and Mixing (Medium Viscosity)
- Petrochemicals (Medium to High Viscosity)
- Lube Oil Blending (High Viscosity)

Construction:

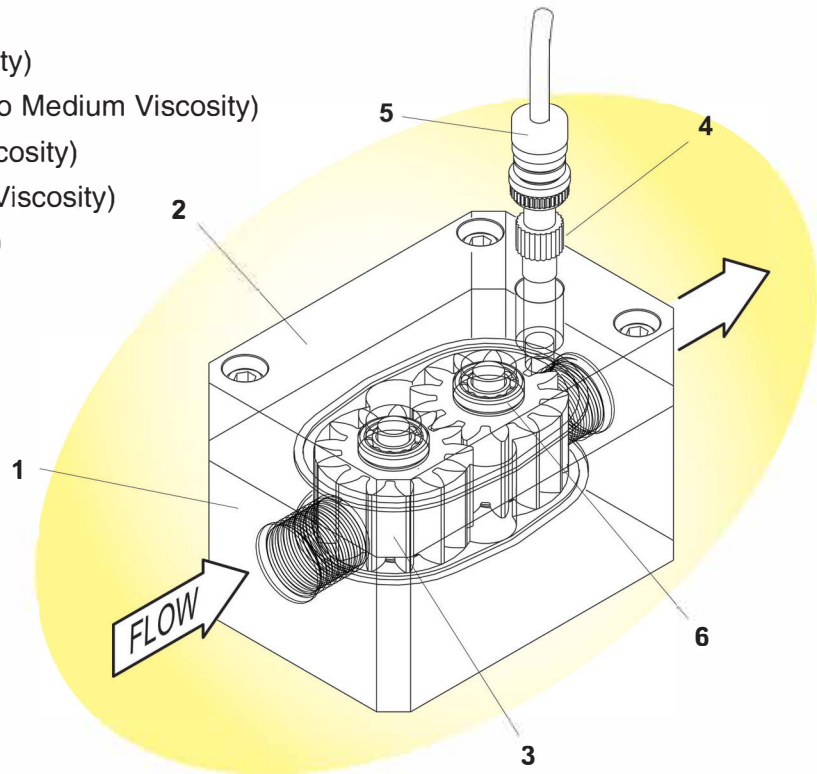

Item #	Description	Material of Construction
1	Housing	304 Stainless Steel
2	Cover	304 Stainless Steel
3	Gear	416 Stainless Steel
4	Pickup Sensor	303 Stainless Steel (Housing) with solid epoxy encapsulation
5	Mating Connector	MS 3102A-10SL
6	Bearing	440C stainless Steel

Note: Other materials are available upon special order

Principle of Operation:

The force of the liquid moving through the flowmeter drives the measuring gears. The liquid stream is divided into the fixed volume cavities between the gear teeth and metering body.

The movement of gear is measured by means of a pick-up sensor located in the cover. When the measuring gears rotate by one tooth pitch, the sensor emits a signal/frequency, which corresponds to the geometrical tooth volume. The signal is converted into a square wave pulse by the pre-amplifier.

The pulse or frequency output are processed by secondary instruments ranging from a basic signal conditioner, indicator/totalizer to more complex flow computers, which compensate temperature, pressure, density, viscosity and provide accurate volumetric or mass flow measurement.

Calibration:

NIST traceable calibrations are performed on the fluid being used in most cases and on simulated blend oil in some cases.

Filtration:

The suggested filtration recommendation is 100 microns or better. A suitable strainer/filter reduce or eliminates the bearing damage by contaminated particles.

Maximum Operating Pressure: 6000 psi

Temperature Limits:

- 40 °F to 221 °F (-40 °C to 105 °C)
- 40 °F to 400 °F (OPTIONAL)

Electrical Output:

Type of Pick-up	Electrical Output	Supply Voltage	Electrical Connection
Magnetic Pick-up	30 mV peak to peak at minimum linear rate	Not Required	MS 3102A-10SL-4P or 2-wire pigtails for explosion proof option
Modulated Carrier Pickup coupled with pre-amplifier	5 TTL/CMOS, Open Collector, PNP, NPN, 0 –5v pulse	7 – 30 VDC @ 20 mA max	MS 3102A-10SL-3P or 3-wire pigtails for explosion proof option

Specifications:

Accuracy	Liquid Service * Based on Mil-H-5606
Calibration Accuracy of Primary Standard directly traceable to NIST	+/- .10% of Reading
Repeatability	+/- .05% of Reading
Linearity over Normal Range 100:1 Turn-Down	+/- .50% of Reading

* Consult factory for performance on other liquid

Flow Range:

Model Prefix	Nominal Size (inch)	Flow Range GPM	Approx. Max Frequency Hz	Approx. K Factor P/gallon
FMG-4-8	1/4"	.01 - .50	1000	120,000
FMG-8	1/2"	.10 - 20	480	1,440
FMG-16	1"	.50 - 40	800	1,200
FMG-20	1 1/4"	.50 - 70	800	686
FMG-24	1 1/2"	1 - 110	360	196

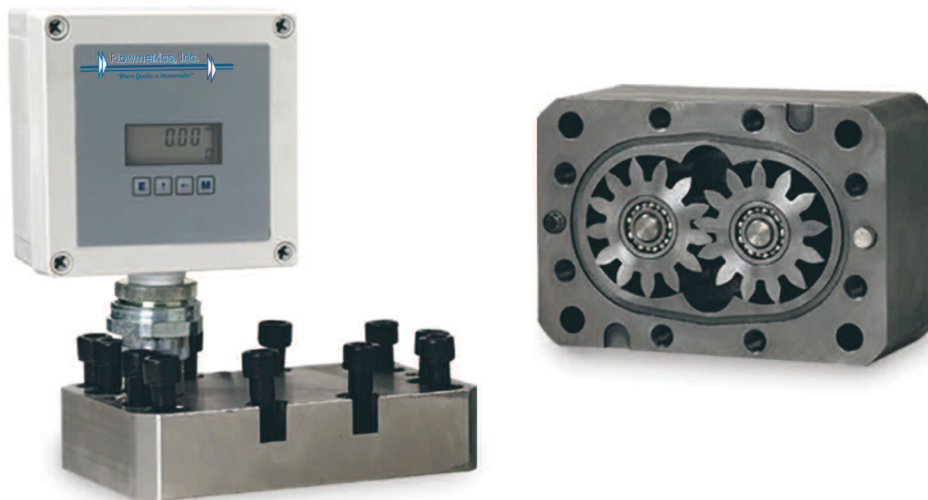

Dimensions:

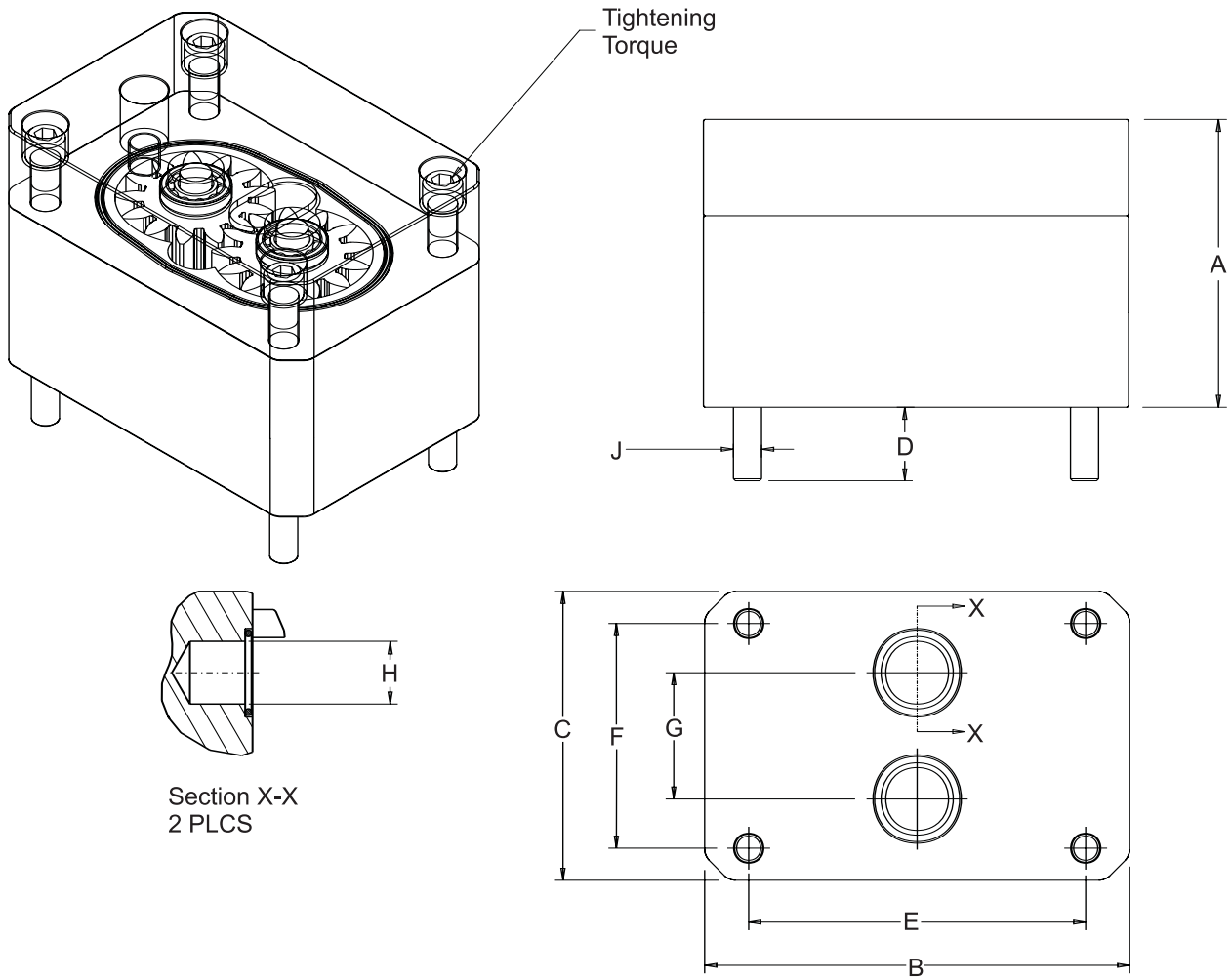

Model Prefix	A	B	C	D	E	F	G	H DIA	J	Torque (ft-lbs)	Weight (lbs)
FMG-4-8	1.95	3.38	2.50	.43	2.750	1.600	.775	.261	1/4-20 UNC-2A	18	6
FMG-8	2.89	4.50	4.00	.75	3.500	3.000	1.218	.500	1/4-20 UNC-2A	18	18
FMG-16	3.85	6.62	4.50	1.12	5.250	3.500	1.968	.975	7/16-14 UNC-2A	106	30
FMG-20	4.48	6.62	4.50	1.12	5.250	3.500	1.968	.975	7/16-14 UNC-2A	106	35
FMG-24	6.94	8.00 DIA	6.56	1.25	4.250	5.625	3.216	1.250	1/2-13 UNC-2A	160	85

NOTES:

1. All dimensions in inches unless otherwise specified
2. Above dimensions are for plate or manifold mounting
3. Consult factory for threaded connection (Pipe or SAE Port)